

When working on your planter in the raised position be certain that service locks are installed or parking stands are down and properly secured. Wear proper protective clothing and eye protection. Review the safety section in your operators manual.

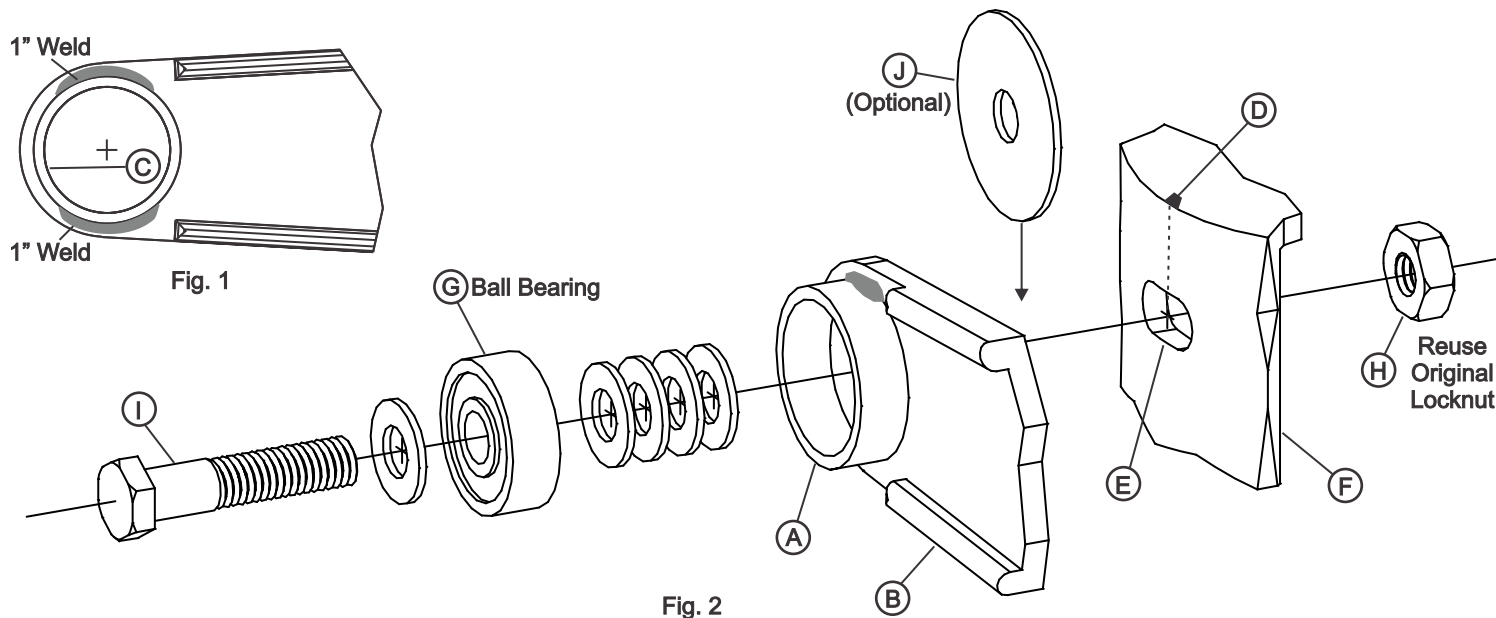

Note: The inside diameter of the bearing housing (A) has been machined to provide approximately .015" clearance with the bearing outer race. This is to allow for some misalignment between the bearings. The bearing outer race will not slip in the housing because the friction between the balls and races is very low in comparison to that between the outer race and housing.

1. Remove closing wheel frame (B) from planter. By unhooking the spring from the planter frame you can avoid disassembling the spring and handle. Grinding approximately 1/4" off the hook may make reassembly easier.
2. Locate the bearing housing I.D. flush with the original hole in the frame at the front (C). Clamp the bearing housing in place.
3. Weld the bearing housing (A) at the top and bottom as shown. Welds should be approximately 1" long.
4. The 1700 support casting sides have a curved surface. This allows the closing wheels to be adjusted while keeping the bearings in alignment. Placing marks (D) centered on slots (E) in support casting (F) will help.
5. Assemble bearing (G) and hardware as shown. Nut (H) is original equipment.
6. Check the alignment of the closing wheels with the center of the row unit. If necessary loosen the capscrew (I) and adjust the frame so the wheels are centered. As the center of one bearing is moved forward of mark (D) the other should be adjusted an equal distance.
7. If the clearance between the closing wheel frame (B) and the support casting (F) seems excessive, one flat washer (J) per side can be inserted between the support casting and frame (B). There should be no pressure between frame (B) and flat washer (J).
8. Tighten the cap screw to 85 ft-lb torque.

### USING THE RKP BALL BEARING KIT ON NEW 1700 PLANTERS

If this kit is used on new 1700 planters no bearing housing (A) is required. Installation is the same as above except for the bearing housing and fewer flat washers are used as shown in figure 3.

